

SITE PLAN
SCALE: 1" = 30'-0"



PROJECT CRITERIA

SCOPE OF WORK: CONSTRUCTION OF A NEW OPEN SIDED CANOPY STRUCTURE FOR WEATHER PROTECTION. ASPHALT PAVING TO REMAIN.

TAX ACCOUNT NO.: 00746300000800

LEGAL DESCRIPTION:
Section 15 Township 31 Range 05 Quarter NE AIRPORT - 37 BLK 000 D-00 - FDP COMBINED FOR TAX PURPOSES ONLY - LOT 8 AS DELINEATED ON CITY OF ARL BLA SURV Z-06-008-BLA REC AFN 200607265247 BEING APTN OF LOT 8 OF EXIST PLAT & T&W FDP - LOT 9 AS DELINEATED ON CITY OF ARL BLA SURV Z-06-008-BLA REC AFN 200607265247 BEING A PTN OF LOTS 8 & 9 OF EXIST PLAT

CODES
2018 INTERNATIONAL BUILDING CODE (IBC)
2018 INTERNATIONAL MECHANICAL CODE (IMC)
2018 INTERNATIONAL FIRE CODE (IFC)
2018 UNIFORM PLUMBING CODE (UPC)

BUILDING CRITERIA
ZONING: G1 (GENERAL INDUSTRIAL)
OCCUPANCY: H-4
CONSTRUCTION TYPE: I1B (FIRE SPRINKLED AND ALARMED)
MAX. BLDG. HEIGHT: 50' (PER ZONING CODE)
LOT AREA: 3.83 ACRES (166,835 SQ. FT.)
BUILDING AREA:
EXISTING BUILDING: 36,256 S.F.
NEW CANOPY: 19,000 S.F.
TOTAL BUILDING AREA: 55,256 S.F.



VICINITY MAP
NOT TO SCALE



Date:	20 JAN 2022	PRE-APPLICATION SUBMITTAL
For:	31 MAR 2022	DESIGN REVIEW SUBMITTAL



2812 Colby Avenue
Everett WA 98201
(425) 252-2153 P
www.2812architecture.com

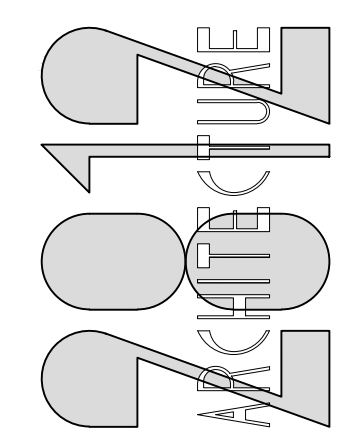

A new canopy structure for:
SEATTLE GALVANIZING
6010 199th Street NE
Arlington, Washington

Drawing:	A 1.1
Job Number:	21c-4832