

DRAWN BY: FERN LIDDELL

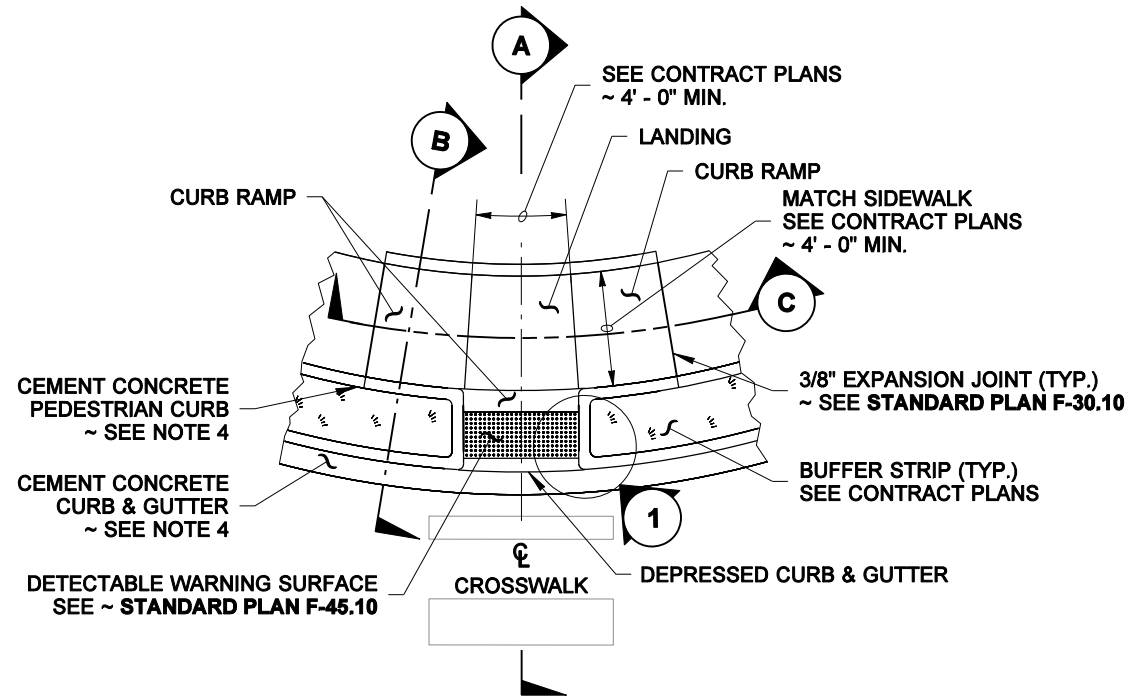

**PLAN VIEW
TYPE COMBINATION
WITH BUFFER**

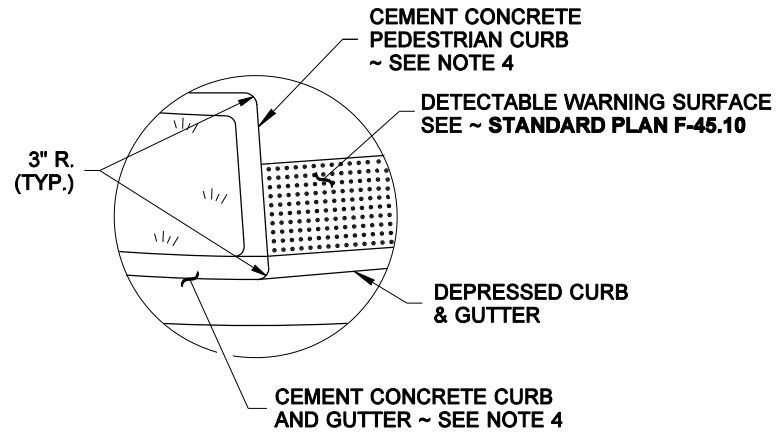

CURB RADIUS DETAIL 1

NOTES

1. Provide a separate curb ramp for each marked or unmarked crosswalk. Curb ramp location shall be placed within the width of the associated crosswalk, or as shown in the Contract Plans.
2. Where "GRADE BREAK" is called out, the entire length of the grade break between the two adjacent surface planes shall be flush.
3. Do not place gratings, junction boxes, access covers, or other appurtenances in front of the curb ramp or on any part of the curb ramp or landing.
4. See Contract Plans for the curb design specified. See **Standard Plan F-10.12** for Curb, Curb and Gutter, and Pedestrian Curb Details.
5. See **Standard Plan F-30.10** for Cement Concrete Sidewalk Details. See Contract Plans for width and placement of sidewalk.
6. The Bid Item "Cement Concrete Curb Ramp Type ___" does not include the adjacent Curb, Curb and Gutter, Pedestrian Curb or Sidewalks.
7. The curb ramp maximum running slope shall not require the ramp length to exceed 15 feet to avoid chasing the slope indefinitely when connecting to steep grades. When applying the 15 foot max. length, the running slope of the curb ramp shall be as flat as feasible.
8. Curb ramp, landing & flares shall receive broom finish. See **Standard Specifications 8-14**.

LEGEND

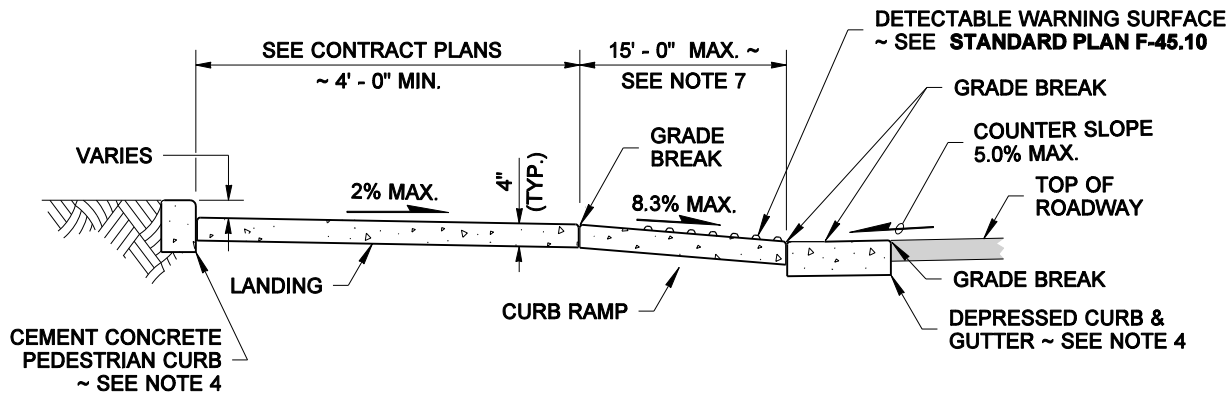

SECTION A

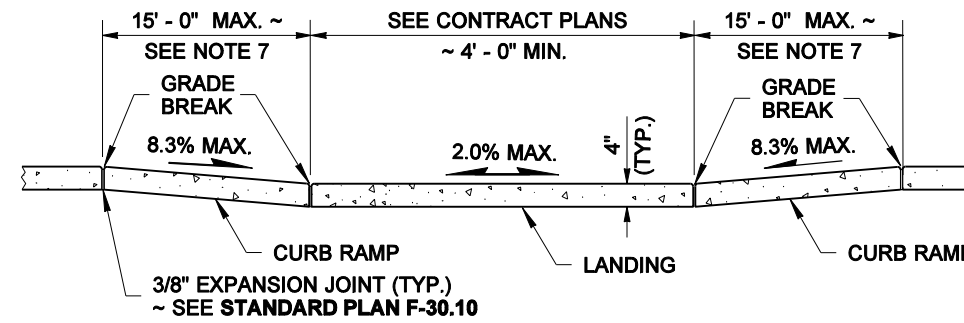

SECTION C

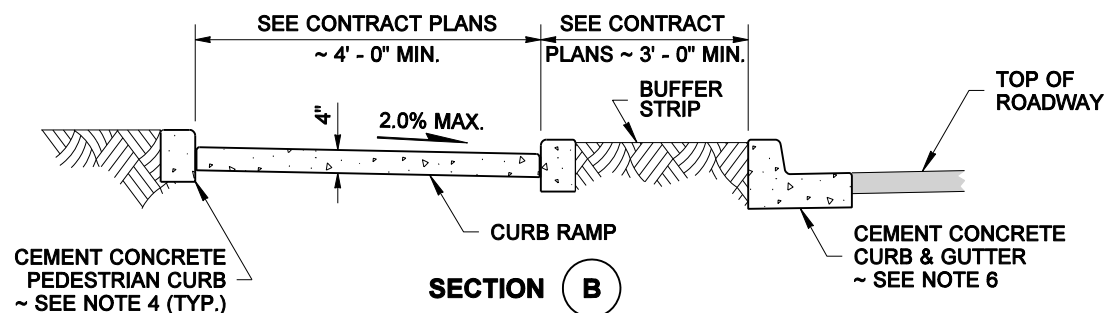

SECTION B

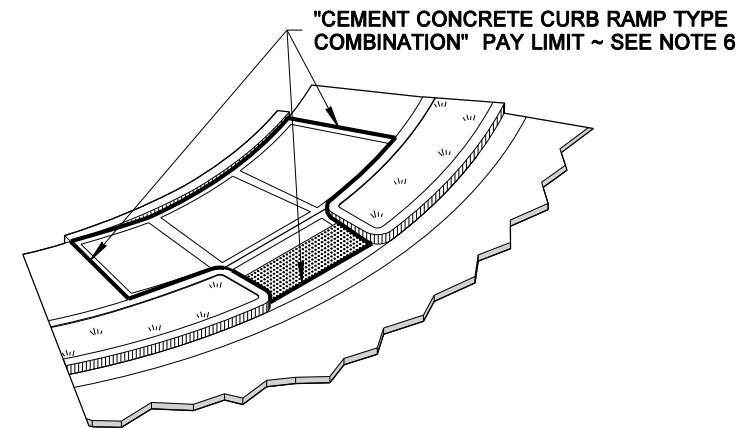

**ISOMETRIC VIEW
TYPE COMBINATION
PAY LIMIT**

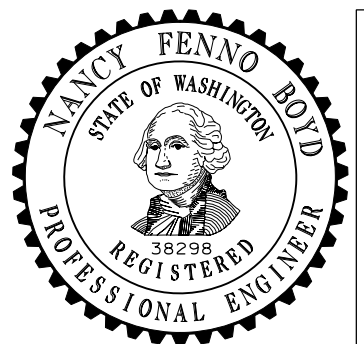

NOTE: THIS PLAN IS NOT A LEGAL ENGINEERING DOCUMENT UNTIL IT IS APPROVED AND SEALED BY THE ENGINEER. THE ENGINEER'S APPROVAL IS VALID ONLY IF THE ENGINEER HAS FILED HIS OR HER STATEMENT OF TRANSPORTATION. A COPY MAY BE OBTAINED UPON REQUEST.

**COMBINATION
CURB RAMP
STANDARD PLAN F-40.14-01**

SHEET 1 OF 1 SHEET

APPROVED FOR PUBLICATION

Pasco Bakotich III 06-03-10
STATE DESIGN ENGINEER DATE

