

**ELEVATION**

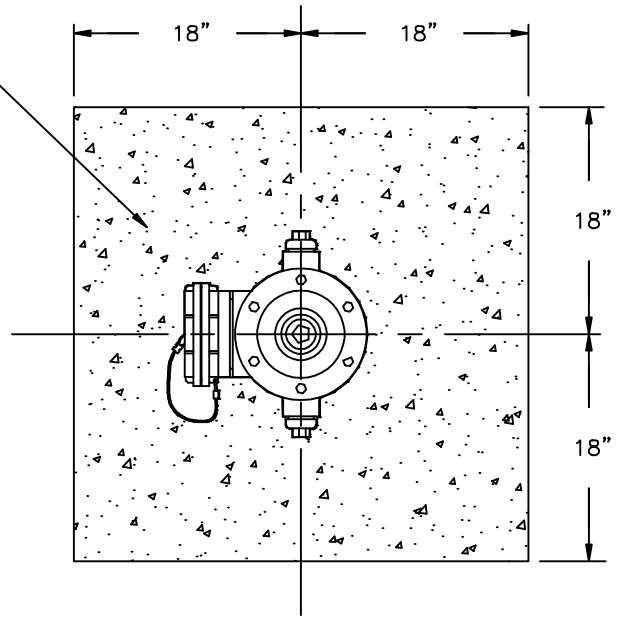

**PLAN**

**NOTES:**

1. CONCRETE SHALL BE CLASS 3000 PSI MIN.
2. INSTALL 1/4" EXPANSION JOINT MATERIAL WITH FULL DEPTH OF CONCRETE PAD AROUND HYDRANT.



APPROVED BY	L. OLIVE
DATE	07/31/2008
REF STAD SPEC	

DEPARTMENT OF PUBLIC WORKS  
**STANDARD DETAILS**

---

**FIRE HYDRANT CONCRETE PAD**

STANDARD DETAIL  
NUMBER  
**W-020**